

**TECHNICAL AND HEATING SPECIFICATIONS**

H2OCEANO is designed to heat water by the combustion of wood in the hearth.  
 The water contained in the thermo fireplace is heated and sent into the heating system (radiators, heated towel rails, underfloor or heating panels) and also heats the room in which it is located via natural convection radiation.  
 The thermo fireplace **MUST NEVER FUNCTION WITHOUT WATER IN THE SYSTEM.**  
 The water heats up, circulating in the cavity that runs around the entire semi-circular wall and dome of the hearth.  
 The hollow space is constructed in thick steel sheet.  
 The hearth is closed in the front by a door that slides up and down and side to side for cleaning the glass.

**INNOVATIVE PATENTED ASH GRILLE**

This allows for the distribution of primary combustion air not only from the bottom up, but also horizontally to achieve high oxygenation of the flame, better combustion and increased power.

**“GASKET-SAVING” DOOR**

During sliding, the door remains slightly ajar from thermo fireplace inlet in order to protect the gaskets. In the closed position the door is perfectly flanked against the thermo fireplace to ensure maximum sealing and therefore optimal performance. The handle is removable or it can be fixed to the door (see pg. 28)

**AUTOMATIC SMOKE BY-PASS**

When turning on with the frame open, to facilitate combustion start-up, the smoke damper (S) remains in the opening position so that smoke can directly and easily reach the chimney flue.  
 When combustion has been started up, the smoke damper also closes automatically when the door is closed (S - fig. b). In this mode, before reaching the chimney flue, the smoke deviates in such a way to lap and give off heat to the water in an efficient manner.  
 The by-pass is automatically controlled by the door’s movement.

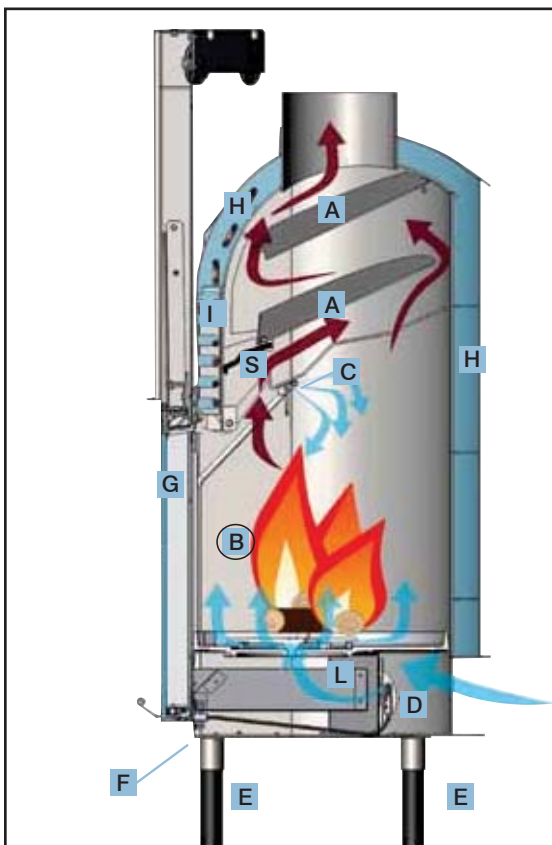
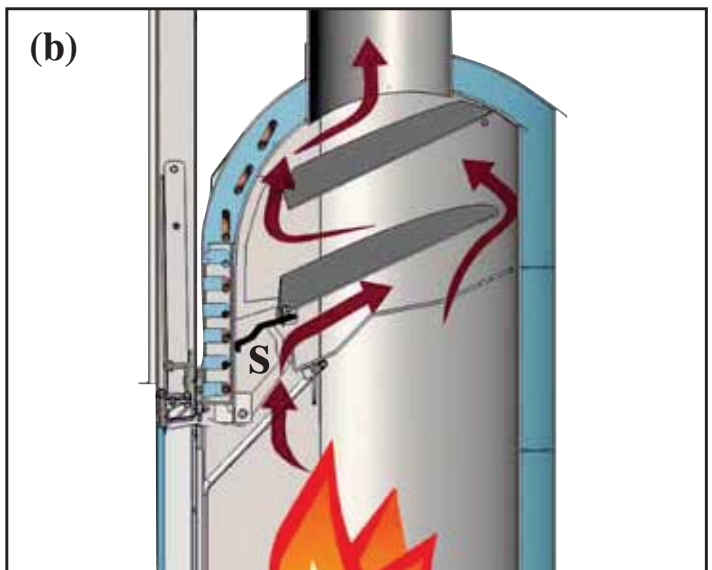
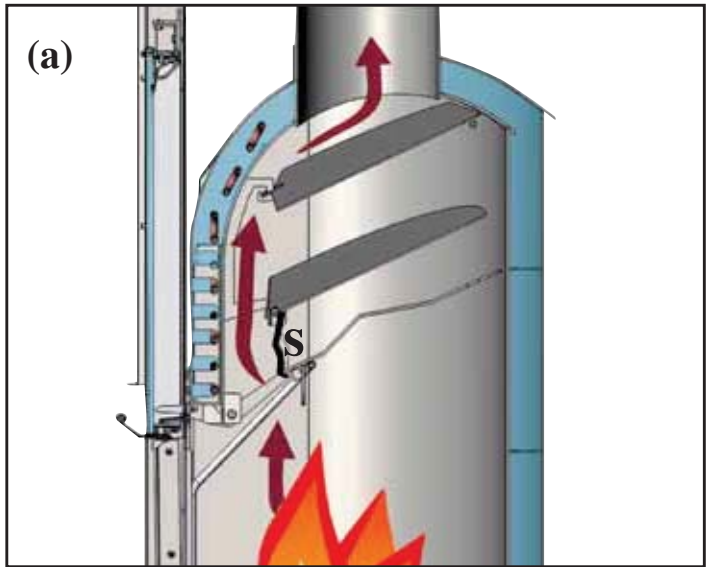

- A** Deflectors/Ceilings
- B** Grill motor housing
- C** Post-Combustion
- D** Automatic external air inlet adjustment valve (optional)
- E** Possibility of applying adjustable feet (optional)
- F** Calibration for automatic adjustment of combustion air
- G** Up/down sliding door
- H** Enveloping cavity for water containment
- I** Safety coil for thermal relief (CS version)
- L** Primary combustion air distribution ash grille
- S** Smoke diversion damper

# DIMENSIONS

FRONT

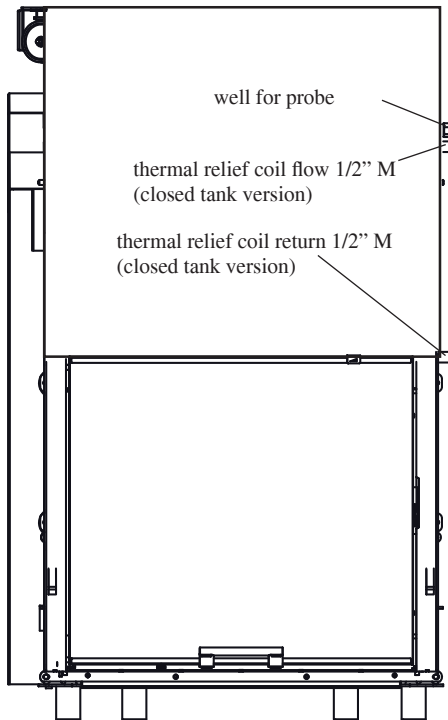

SIDE

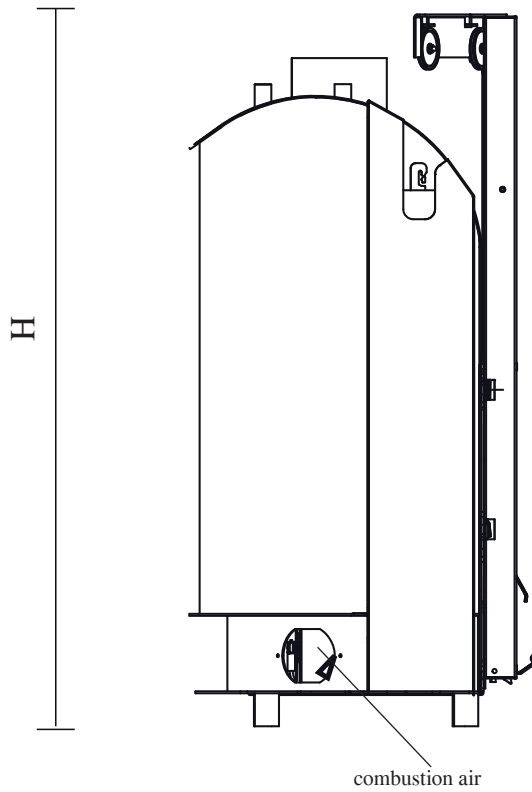

SYSTEM

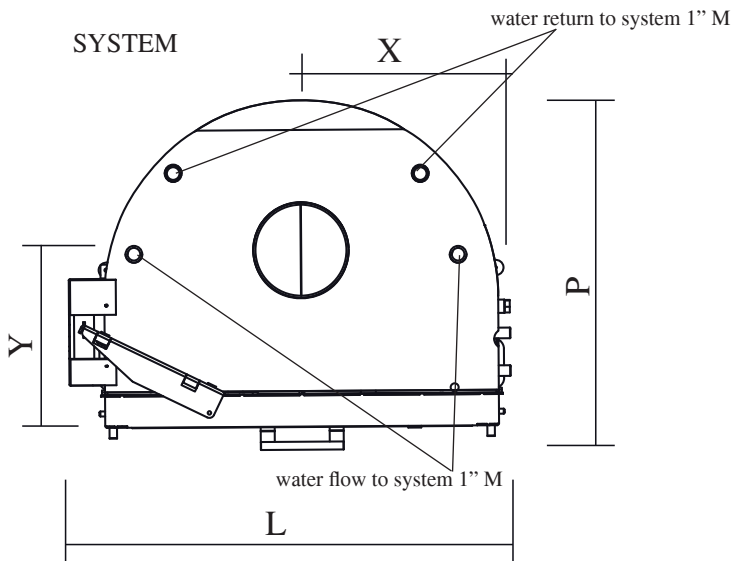

L	88	cm
P	68	cm
H	147 without feet (with feet + 14 cm)	cm
X	34	cm
Y	37	cm
internal hearth dimensions	60x50	cm

**THE INLET AND OUTLET PIPES MUST BE CROSSED FOR THIS TO FUNCTION PROPERLY**

# TECHNICAL AND HEATING SPECIFICATIONS

ENGLISH

Thermal output (burnt)	27,8	kW
Rated power	22,2	kW
Water heating power	18,2	kW
Approx. overall efficiency	80	%
Approx. water efficiency	82	%
Class efficiency (EN 303-5)	> 3	-
∅ female smoke outlet	22	cm
Maximum operating pressure	1,5	bar
Fuel consumption	7	kg/h
Water capacity	100	litres
Heating capacity *	535	m <sup>3</sup>
Weight including packing	285	kg
Hot sanitary water production (kit 1- 3 - N3 - N3bis)**	13-14	litres/min
∅ external air inlet	12,5	cm
System return (male)	1"	inches
System flow (male)	1"	inches

**N.B.: DATA PROJECT (Refer to standard EN 13229)**

\* The heatable room dimensions are calculated on the basis home insulation in compliance with Italian law 10/91, and subsequent changes together with an expected heat output of 33 Kcal/m<sup>3</sup> per hour.

\* It is also important to consider the position of the boiler-fireplace in the room to be heated.

\*\* boiler temperature is 70° - (∂T=25K)

**THE INLET AND OUTLET PIPES MUST BE CROSSED FOR THIS TO FUNCTION PROPERLY**

**The data shown above is purely indicative.**

**EDILKAMIN s.p.a. reserves the right to change the products at its discretion without notice.**

